

Gripping suction cups
Economic blowing
& Booster blowing

Venturi systems
Vortex tubes

French specialist
in industrial
vacuum technology

no
va
com

Find us on



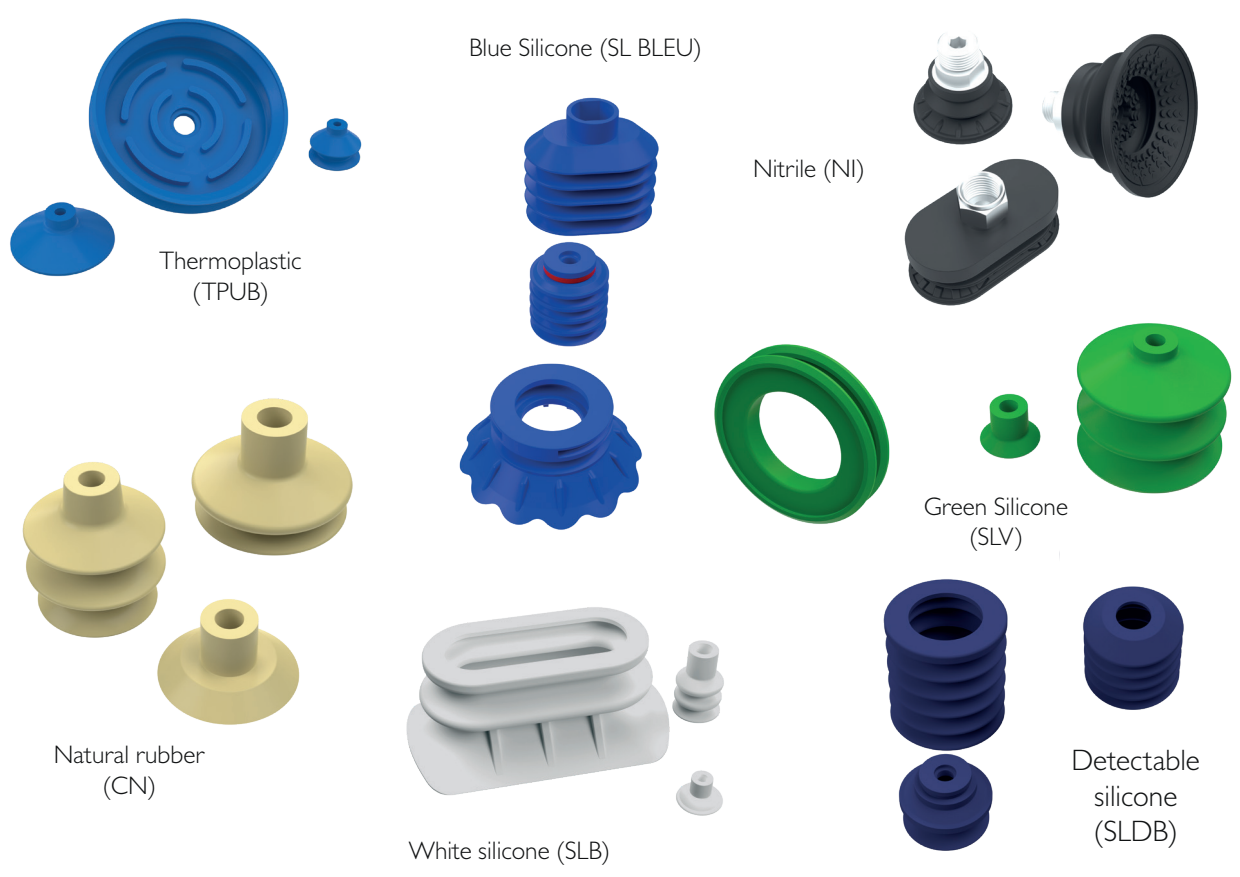

The suction cup connects the workpiece to the gripping system. It is the difference between the vacuum created inside the suction cup and atmospheric pressure that allows the suction cup to adhere to an object. This pressure difference is achieved by connecting the suction cup to a vacuum generator, also known as a venturi.

GENERAL SELECTION CRITERIA

To properly choose the suction cup, several parameters must be considered:

- **the shape of the workpiece:** flat, curved, cylindrical, wavy, ...
- **the material of the workpiece:** porous, deformable, rigid, flexible, or fragile, ...
- **the condition of the workpiece surface:** abrasive, grainy, smooth, ...
- **the appearance of the workpiece:** oily, dusty, dry, viscous, wet, ...
- **the mass of the workpiece,**

- **the temperature of the workpiece,**
- **the orientation of the grip:** horizontal, vertical, angular, level differences, ...
- **the type of grip:** handling, lifting, depalletizing objects, holding, ...
- **available surface,**
- **cycle times.**

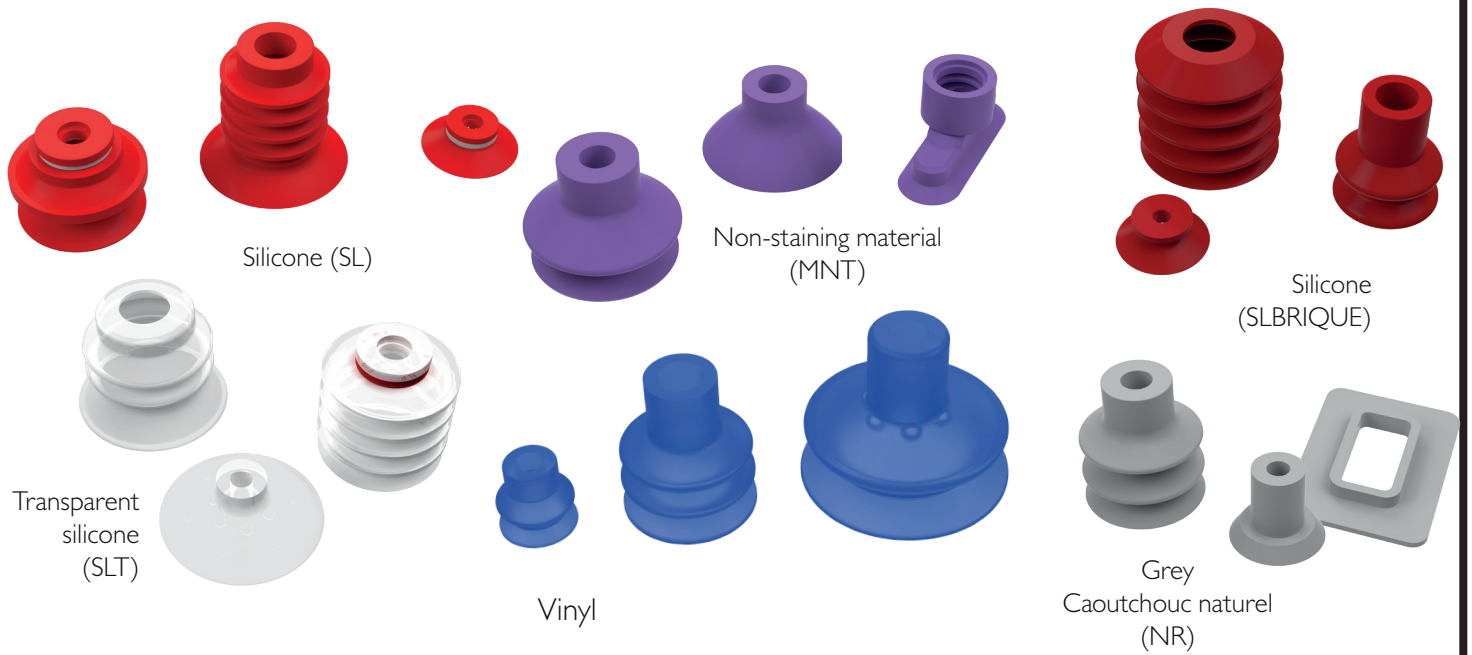

+ 40
different materials

+ 5000
references

Numerous inserts in different materials

NOVACOM is a French manufacturer of industrial suction cups for automation systems and production lines, offering the largest range in Europe. For optimal vacuum gripping, our range is complemented by other components: inserts, supports, and various accessories.

Vacuum gripping ensures the fast handling of a wide range of fragile or complex-shaped objects. FDA and/or CE certifications are available for selected suction cups. Please let us know when placing your order if you require certification.

We develop upon request all types of gripping suction cups or technical parts...

Custom inserts in aluminum, brass, stainless steel, nickel-plated brass, or detectable material...

For any request, contact a NOVACOM expert via our website:

www.novacom-vacuum.com

Single-stage VENTURIS

Compact and easy installation for independent and localized vacuum, as close as possible to the suction cups.

VCR-2 • VCR-2 EV

These venturis are **ideal in dusty environments** thanks to their anti-clogging technology. Equipped with a solenoid valve, they are perfect for high-speed processes (110 to 340NI/min of air suction). Discover **our new version, equipped with two solenoid valves**. It allows more effective back-blowing.



VCR-2

VCR-2 EV

NEW ANTI-CLOGGING VENTURIS FOR REDUCED MAINTENANCE!

We have added a **second solenoid valve to the anti-clogging venturi (VCR EV CS)**, allowing it to adapt to the **high production speeds** by breaking the vacuum more quickly. The back-blowing also helps expel particles that would not be removed by the exhaust.

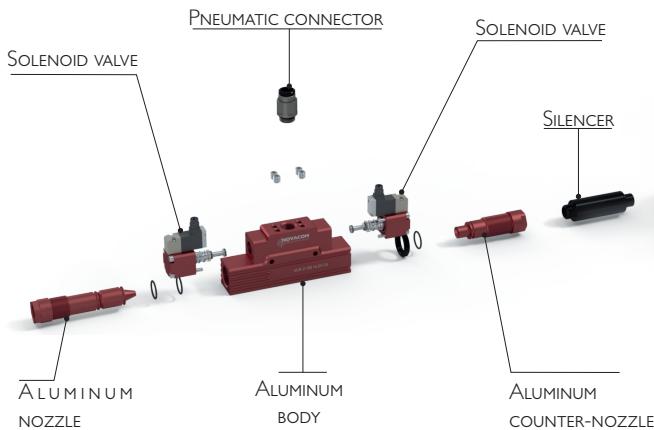

PERFORMANCES OF VCR-2 /EV & VCR-2 EV CS

Pressure (bar)	6
Air consumption (NI/min)	120 to 340
Sound level (dB)	82
Vacuum (%)	85
Suction (NI/min)	110 to 340

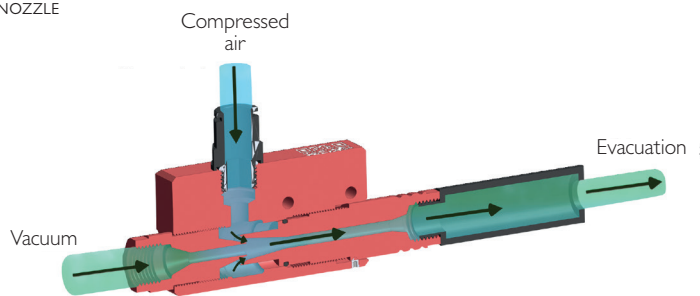

Multi-stage VENTURIS

High performance and large suction airflow for economical compressed air consumption.

PVP NEED HIGH SUCTION CAPACITY?



We offer a full range of pneumatic vacuum pumps "PVP" that use 3-stage multi-cartridge technology, which allows for the best possible performance: **reducing the air consumption**. Our models are made entirely of aluminum and are equipped with 2 to 12 cartridges **to achieve up to 4,032 NI/min of air suction and 93% vacuum!** This design allows our products to adapt to all industries (pharmaceutical, food processing, bottling, metallurgy, etc.). Our PVP units will easily integrate into your systems and are fully dismantlable for easy maintenance.

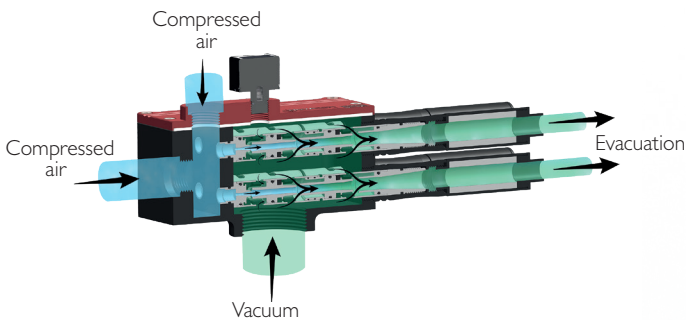
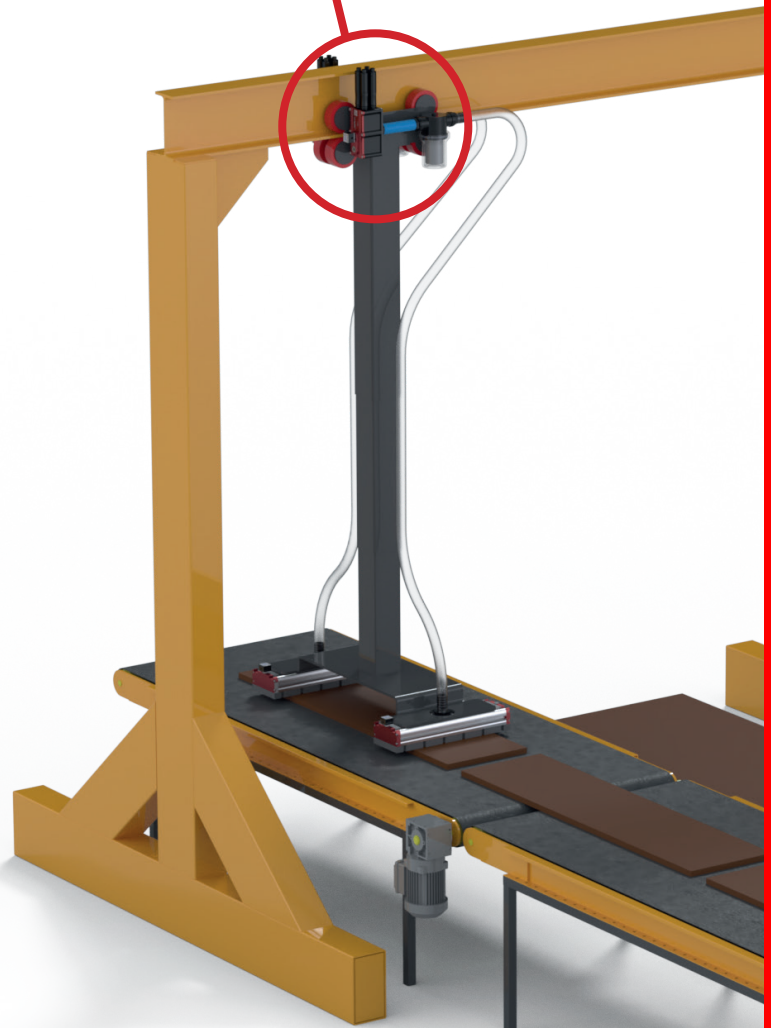
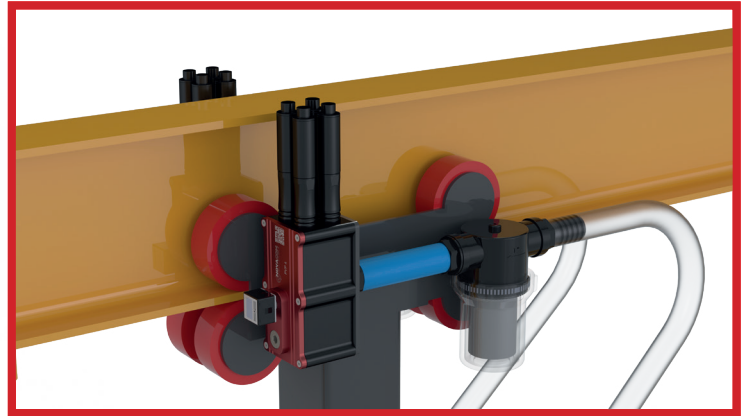

PERFORMANCES OF PVP 2/4/6/8 & 12

Pressure (bar)	6
Air consumption (NI/min)	273 to 1280
Sound level (dB)	82
Vacuum (%)	90 to 93
Suction (NI/min)	640 to 4032

PVP 2 • PVP 4 • PVP 6 • PVP 8 • PVP 12

eiectors

VACUUM BOX CVM *Edition*

VACUUM BOX
with ejectors
and counter blowing



Here are some examples
of how to use our range
of vacuum boxes.

**Vacuum box
with venturis and blowback**

Dimensions : 130x300mm

CVM 130x300 CS ED

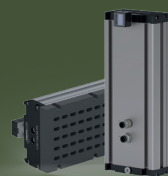

**Vacuum box
with venturis
and blowback**

Dimensions : 130x600mm

CVM 130x600 CS ED



**Vacuum box
without venturis**

Dimensions : 130x800mm

CVM 130x800 SV ED

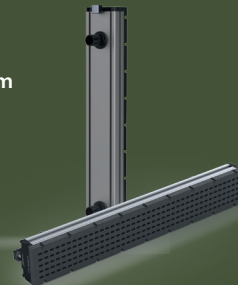

Other dimensions on request (excluding offer).

**Vacuum box
with venturis and
blowback**

Dimensions : 130x400mm

CVM 130x400 CS ED



TAILOR-MADE VACUUM BOX

SOLUTIONS TAILORED TO YOUR NEEDS

Tailor-made vacuum box

Dimensions : 110x600mm

CVSA 110X600 PSM 42



Tailor-made vacuum box

Dimensions : 260x400mm

CVSP 260X400SVM 20



Tailor-made vacuum box

Dimensions : 130x70mm

CVSA 130x70 PSV 10

Tailor-made vacuum box

Dimensions : 110x310mm

CVSA 110X310 PVM 22

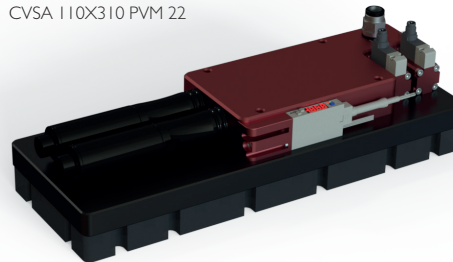

Tailor-made **vacuum box** are the ideal solution to meet the specific needs of your industrial applications. Whether for gripping, handling, or packaging tasks, these systems offer versatility and adaptability.

MAIN FEATURES

Custom design:

Our tailor-made vacuum box are manufactured according to your dimensions and technical requirements. Each box is optimized for its intended application, ensuring maximum performance.

VACUUM TECHNOLOGY OPTIONS

With or without **venturi**
With or without **ball sensor**
With or without **counter blowing**
Foam suction cups
Compartmentalized zone

ADVANCED EMBEDDED TECHNOLOGIES

Possible installation of **solenoid valves**
Integration of **vacuum measurement devices**

SUITABLE FOR ALL INDUSTRIES

Whether you operate in the food, automotive, cosmetic, pharmaceutical, or packaging sectors, our customized boxes are perfectly suited to your specific needs. Each solution is designed to meet the quality and performance standards demanded by your industry.

BOOSTER BLOWING

Air amplification up to 25:1

Without modifying your compressed air network, achieve a significant increase in blowing power, essential for improving productivity.

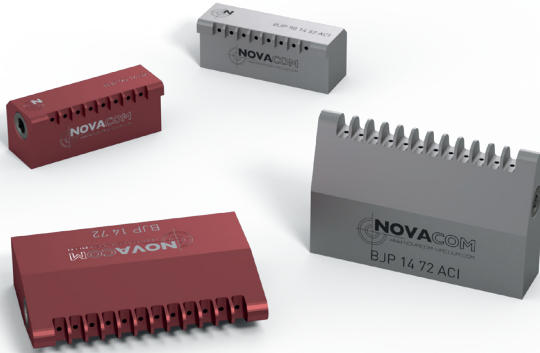

FLAT JET AIR NOZZLE AND 90° FLAT JET AIR NOZZLE

Flat jet nozzles are specially designed **to amplify the compressed air flow**. Their specific shape allows the compressed air flow to draw in ambient air, which adds to the initial airflow. Perfect for **ejection, cleaning, or part cooling operations**.

Operating on the same principle as flat jet nozzles, these blow-off nozzles, with the air flow directed at 90°, provide a more compact design.

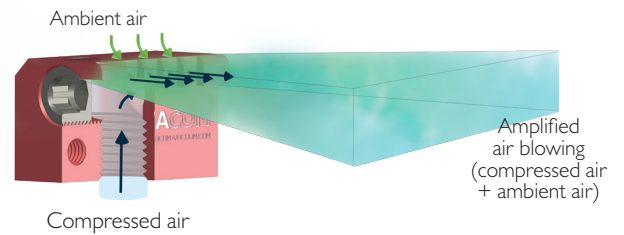
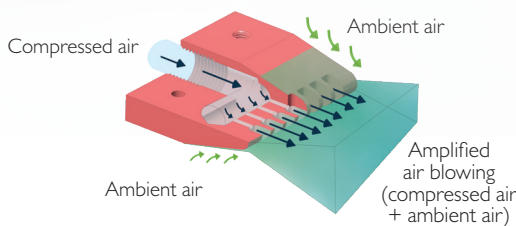

blowing



DIRECT JET BLOWING NOZZLE

Used to amplify the compressed air flow at the output, round jet nozzles (with booster effect) provide high thrust while consuming only a fraction of the compressed air typically used by open pipe systems. These nozzles can be installed on blowers or directly on production lines.

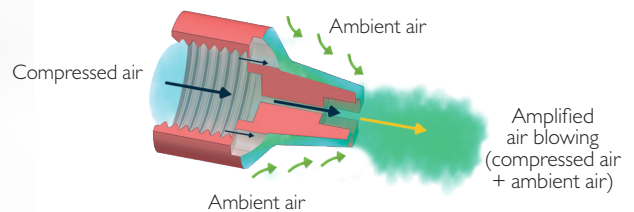
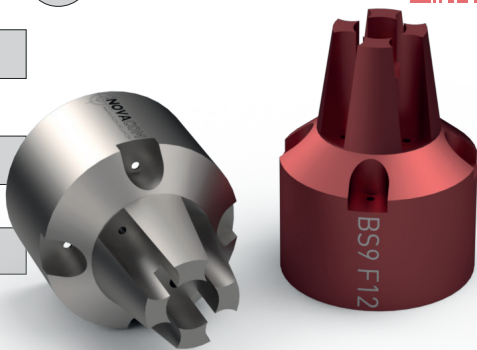

NEW

Controlled system for FLAT JET NOZZLES: BJP EV

By integrating a solenoid valve at the heart of the nozzle, this innovative technology provides an extremely short air flow response time. Compact, these nozzles are ideal for optimizing space on your production lines. Their ease of installation and maintenance makes NOVACOM controlled nozzles an essential asset for all your projects.



ECONOMIC BLOWING

Reduce your compressed air consumption by up to 70%

Achieve the same blowing performance with lower compressed air consumption, and save costs.

ROUND JET BLOWING NOZZLES (BS)



Round jet nozzles (BS) produce a powerful circular air jet while minimizing compressed air consumption. They consume up to 70% less compressed air compared to an open pipe. The flow and pressure are adjustable and easily controllable.

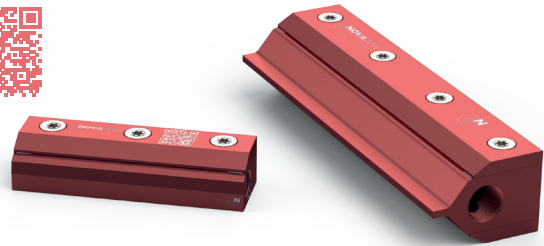
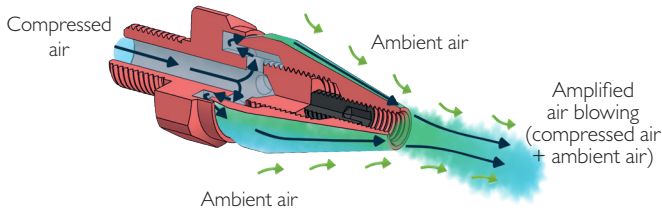

Single flow, double flow AIR CURTAINS (RA-3 ; RA-2 DF)

NOVACOM air curtains allow cooling or cleaning of large surfaces without generating excessive noise or causing excessive compressed air consumption. It is also possible to create an air barrier to separate areas with different temperatures or prevent cross-contamination.

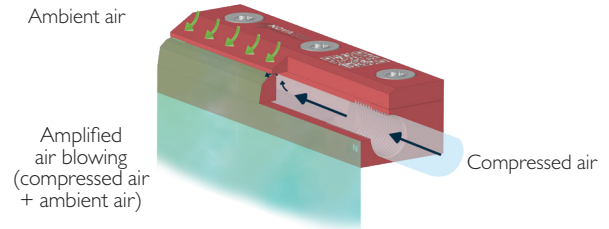

AIR CURTAINS Circular (RAC)

Circular air curtains are specially designed for blowing operations on profiled elements. They provide optimal and uniform distribution of the airflow across the entire perimeter without excessive compressed air consumption.

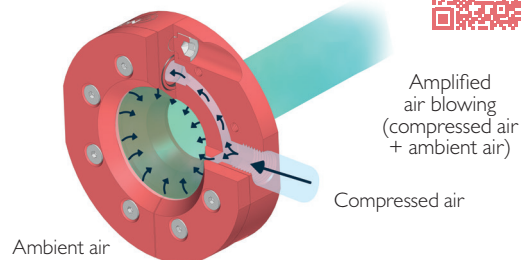
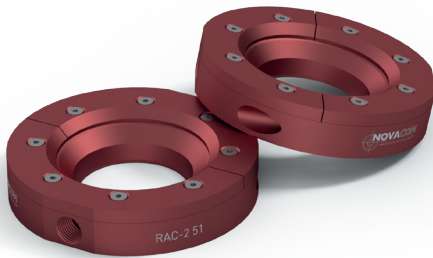

Ionizing AIR CURTAINS

Ionizing blowing allows for the neutralization of electrostatic charges and the expulsion of contaminant particles. Compressed air-powered ionizing air curtains can perform static dusting over a wide area.

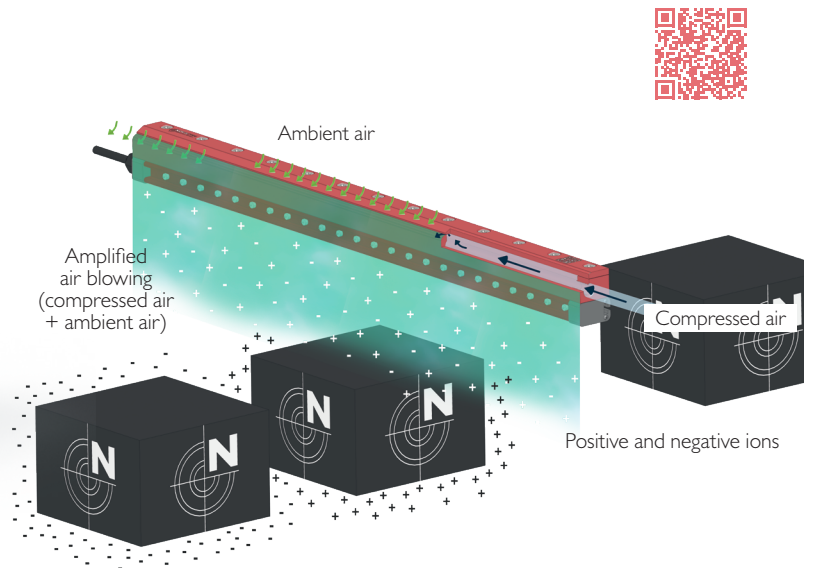

transport

AA 004 • AA 008 • AA 015 • AA 025 • AA 030

AIR AMPLIFIER - AA

For smoke transport and extraction.



Air amplifiers are essential tools for various blowing operations such as ejection, smoke or vapor extraction, and pneumatic transport over short distances with a fast airflow.

These devices can increase the airflow speed in applications like cleaning, where they dislodge debris more effectively than compressed air alone.

Additionally, their extraction power can be used to efficiently eliminate smoke, dust, and other particles in industrial cleaning or ventilation applications.

In pneumatic transport operations, they can be used to transport a wide range of materials, from powders, plastics, to grains, over long distances without relying on complex mechanical systems. These amplifiers ensure gentle and secure handling of materials, reducing potential damage to products.

Compressed air

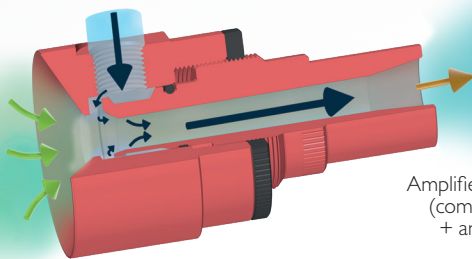

Surrounding air

PNEUMATIC TRANSPORT - TP

Designed for transporting materials over long distances using compressed air.

Energy-efficient, our venturis are perfect for pneumatic transport, allowing the suction and transfer of various materials over long distances (powders, granules, steel balls, wood chips, etc.). Made from aluminum or stainless steel, they are available in various sizes, making it easy to integrate them into your piping systems. The maximum transport length

depends on the product density and the installation geometry (bends, etc.). For long-distance transport, it is recommended to install the TP venturis in series.

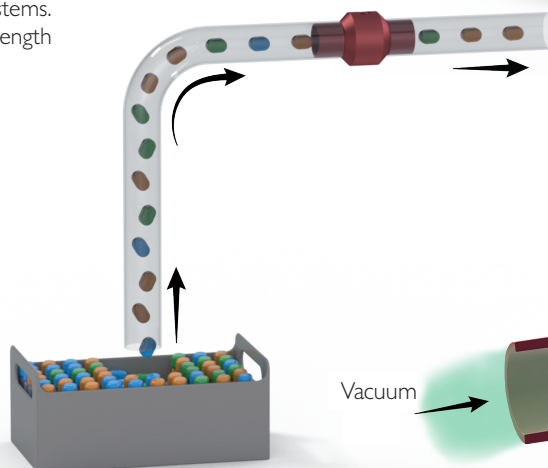

TP 19 • TP 25 • TP 38 • TP 51 • TP 76 • TP 102 • TP 152

vortex tube



VORTEX TUBE

Cooling down to **-40°** compared to the compressed air temperature

* The temperatures are provided for informational purposes for a TV10 cold air gun with a GEA 10R generator - yellow or GEA 15R - red. T° Ac = Compressed air temperature.

Operating with compressed air, these devices are particularly effective for cooling small areas or small volumes.

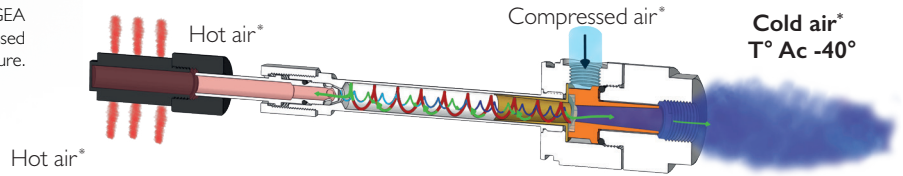

The NOVACOM Vortex range is maintenance-free, as it has no mechanical parts, which greatly reduces downtime on your production lines.

CS Localized and controlled cooling

These cold air guns are designed to provide an air source with a temperature delta suited to each application, depending on the Vortex generator used. They are equipped with articulated hoses for localized and precise use, as well as magnetic bases for easy installation.

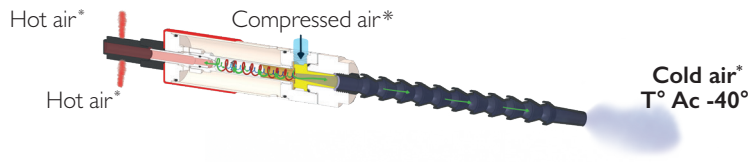

* The temperatures are provided for informational purposes for a CS10 cold air gun with a GEA 10R generator - yellow or GEA 15R - red. T° Ac = Compressed air temperature.



CLIM Electrical cabinet protection

Specifically designed for electrical cabinets, our Vortex-effect air conditioners prevent the risk of overheating internal components. They regulate the temperature and maintain a slight overpressure to prevent dust buildup, thus ensuring the longevity of your electronic equipment.

CLIM-2 EL

Cooling kit for electrical cabinets

- Pre-assembled
- Simple installation
- No maintenance or moving parts
- Reliable
- Durable and long-lasting
- Cabinet overpressure
- Regulates temperature
- Temperature delta up to -40°C compared to compressed air temperature

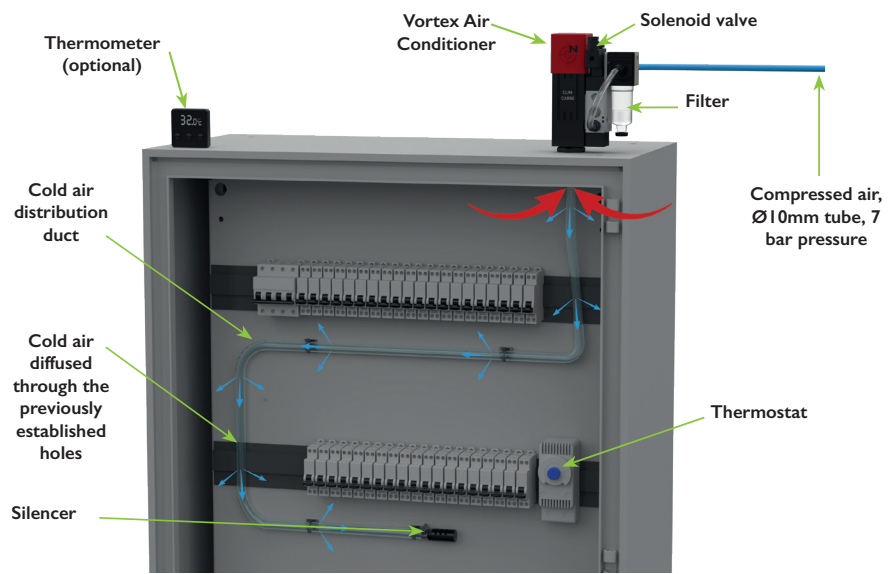

accessories

SUCTION WANDS



Suction wands are air-powered conveying systems that allow the transport of materials such as granules. They are suitable for both long and short distances. Thanks to a pressure regulator, the flow rate of transported products can be adjusted, up to 5kg per minute.

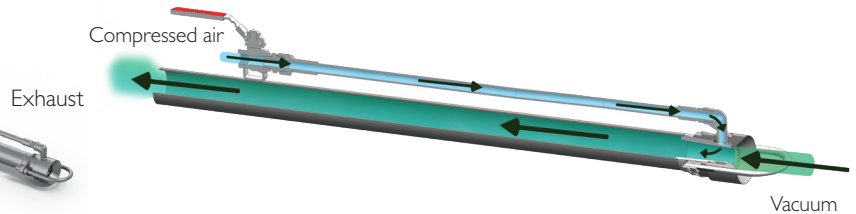

VACUUM REGULATORS (VR)

NOVACOM vacuum regulators limit the fluctuation of the vacuum generated by a venturi system. This ensures a constant vacuum level and secures the entire gripping process. The adjustment knob allows for fine-tuning the vacuum parameters in the system to suit your applications.



SPRING ASSEMBLIES

NOVACOM spring assemblies cushion the contact between the suction cup and the workpiece. Our anti-rotation spring assemblies ensure stability during gripping and support continuous working loads.



PNEUMATIC GUNS

NOVACOM pneumatic guns operate with compressed air and can either suck or blow without electrical power or moving parts. Ideal for suctioning all types of debris, with recovery in a canvas bag. It is also possible to transport materials via a hose to a container or bin. By simply inverting its valve, the pneumatic gun switches to blower mode, providing a very high air flow with low pressure and low consumption.



FILTERS

To ensure optimal performance and longevity of vacuum systems, it is essential to filter impurities that may pass through them (particles, moisture, oils, etc.). The cartridges are interchangeable and come in various materials. Some filters can be fitted into the bellows of the suction cup, others can be mounted on the suction port of venturi systems, or installed in-line on a pipeline.



Z.A. Sars et Rosières • 30 rue de l'Épau • 59230 ROSULT - France
• Phone : +33 (0)3 27 30 53 53 • info@novacom-grp.com



HrTech s.r.o. • Trenčianska cesta 2613/29
957 01 Bánovce nad Bebravou • Slovakia
www.hrtech.sk